



SEDIMENT, DIRT AND AIR SEPERATOR

GENERAL FEATURES

Cleaning and maintenance of the classic strainers are generally neglected by the user. Because, it can not be made easily. This neglect leads to problems such as clogging of the filters and inefficient operation of the system and consequently not being sufficiently heated.

The Ayvaz sediment and dirt separators has two advantages over the classic type of sediment holders:

- The dirt kept in the lower part of the device by filtering. Thus, the system is never blocked.
- The accumulated dirt is easily discharged through the drain valve under the device.

Note: Drain valve should be used for proper and efficient operation of the system.

Body
St 37.2 Carbon Steel

Max. Working Temperature
100°C

Sediment and Air Seperator
AISI 304 Stainless Steel

Connection
Flanged

Max. Working Pressure
10 bar

SEDIMENT, DIRT AND AIR SEPERATOR

TECHNICAL SPECIFICATION

DIMENSIONS(mm)						
DN	L	LK	H	h	KV	HA
65	300	270	475	240	1"	1/2"
80	400	360	600	300	1"	1/2"
100	400	360	600	300	1"	1/2"
125	600	520	800	400	1"	1/2"
150	600	520	800	400	1"	1/2"
200	750	625	1000	500	1"	3/4"
250	850	750	1200	600	2"	3/4"
300	950	850	1500	750	2"	1"
350	1100	1000	1750	875	2"	1"
400	1200	1100	2000	1000	2"	1"

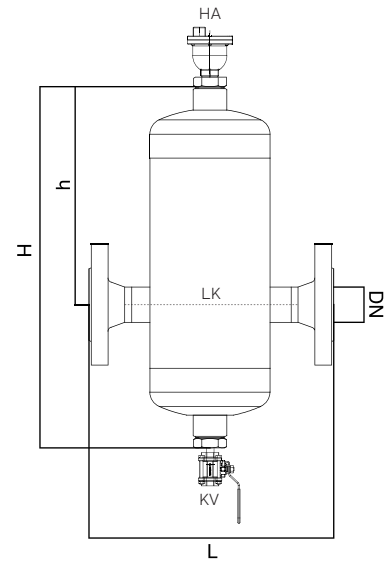

3D APPLICATION SAMPLE

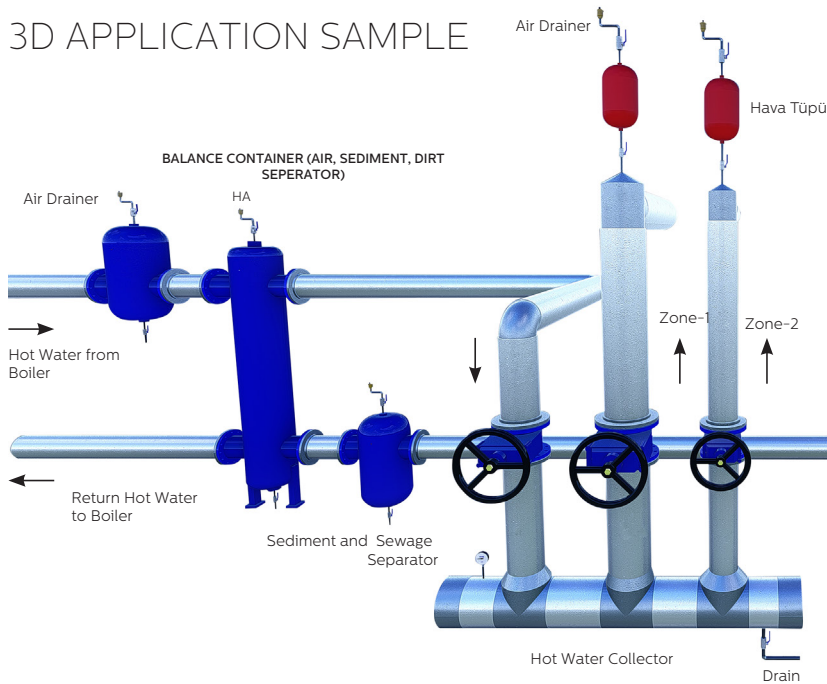

Advantages in Heating and Cooling Systems:

- 3-pack system in one unit,
- Hydraulic balance,
- Air Drainer
- Sediment - Strainer
- Easy to install

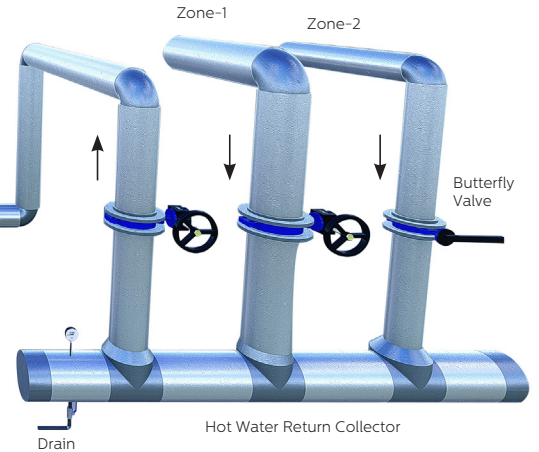

It is placed in the hot water lines at the boiler outlet before the equilibrium vessel.

Installation

Heating Systems :Boiller Output
 Cooling Systems: : Chiller Inlet

SEDIMENT, DIRT AND AIR SEPERATOR

SEDIMENT, DIRT AND AIR SEPERATOR



HEAD OFFICE - FACTORY

Atatürk Sanayi Bölgesi Hadımköy Mahallesi Mustafa İnan Caddesi No: 44 Arnavutköy - İSTANBUL
Tel: +90 212 771 01 45 (pbx) | Fax: +90 212 771 47 27
info@ayvaz.com | www.ayvaz.com

**Cona
Caserta/Italy**

Tel: +39 0823 187 3988
rmolaro@ayvaz.com

**Ayvaz Germany
Viernheim/Germany**

Tel: +49 62046014399
germany@ayvaz.com

**Ayvaz Ukraine
Kiev/Ukraine**

Tel: +380 44 390 57 57
info@ayvaz.com.ua

**Tricorr
Warsaw/Poland**

Tel: +48 530 030 810
+48 533 603 335
tricorr@tricorr.eu

**Ayvaz Azerbaijan
Baku/Azerbaijan**

Tel: +99 (455) 579-84-32
ahayatov@ayvaz.com

**Ayvaz Egypt
Cairo/Egypt**

Tel: +20 122 819 78 29
andrew.eid@ayvaz.com

**Ayvaz Gulf
Dubai/U.A.E**

Tel: +971 563550822
+971 501306871
mideast@ayvaz.com

**Ayvaz China
Ningbo/China**

Tel: +86 152 5830 7361
msahin@ayvaz.com

**Ayvaz Kazakhstan LLP
Almaty/Kazakhstan**

Tel: +7 (727) 327 97 57
info_kz@ayvaz.com

**Ayvaz N
Ispirih/Bulgaria**

Tel: +359 8431 27 32
office@ayvaz-n.eu

**Ayvaz Serbia
Belgrade/Serbia**

Tel: +381 61 658 70 52
yakbiyik@ayvaz.com

**Ayvaz Vietnam
HCMC/Vietnam**

ggursoy@ayvaz.com
Tel: +84 89 8508345

**Ayvaz Americas
Rhode Island/USA**

Tel: +1 401 737 8380
americas@ayvaz.com