



CV 20-25

CHECK VALVE

GENERAL FEATURES

Ayvaz dual flap wafer check valve is designed to operate with the minimum flow restriction. The twin spring loaded half disc operates with the pipeline flow and reseal back against the rubber disc seating. It is providing a positive shut off against any back flow. The resilient seating prevents a slamming action.

ÇV20-25 check valves are produced according to DIN, ANSI, JIS and BS standards.

Ayvaz check valves when compared with order traditional isolating valve such as swing check valve offer the following advantages:

- Low purchase cost
- Compact design
- Non-slam principle of operation
- Light weight
- Easy installation
- Good flow characteristic and less pressure drop
- Suitable for horizontal and vertical up flow

Material Structure:

Body: GG-25 Gray cast iron
Disc: AISI 316 Stainless steel (ÇV20), GGG40.3 ductile iron (ÇV25)

Connection:

Wafer type

Nominal Diameter:

DN50 (2") - DN600 (24")

Working Pressure: Up to 16 bars

Working Temperature:

-10°C to 100°C

Typical Applications:

- Heating air-conditioning pipe lines
- High frequency lines
- Fire extinguishing system
- Vessel pipelines
- Iron and steel industry
- Mineral, oil industry
- Wood working, pulp and paper industry
- Textile industry
- Water and condensate lines

CV 20-25 CHECK VALVE

NOMINAL PIPE SIZE		EXTERNAL DIAMETER ØA	INTERNAL DIAMETER	FACE TO FACE	MAXIMUM WORKING PRESSURE	MAXIMUM WORKING TEMP.
mm	INS	DIN STANDARD				
50	2	109	60	54	16	110
65	2 ½	129	73	54	16	110
80	3	144	90	57	16	110
100	4	164	115	64	16	110
125	5	194	142	70	16	110
150	6	220	169	76	16	110
200	8	275	219	95	16	110
250	10	330	273	108	16	110
300	12	380	324	144	16	110
350	14	440	356	184	10	110
400	16	491	406	191	10	110
450	18	541	457	203	10	110
500	20	596	508	213	10	110
600	24	698	610	222	10	110

Other flanges standard i.e. ANSI, JIS & BIS are available on your request

MAXIMUM NON-SHOCK SERVICE PRESSURE	50 - 300 mm	350 - 600 mm
SEAT TEST PRESSURE (BAR)	13.7	10
SHELL TEST PRESSURE (BAR)	20	16

DIMENSIONAL OF GASKET															
VALVE SIDE	mm	50	65	80	100	125	150	200	250	300	350	400	450	500	600
	INS	2	2 ½	3	4	5	6	8	10	12	14	16	18	20	24
O.D.	Refer to valve external diameter ØA														
I.D.	mm	60	73	90	115	142	169	219	273	324	356	406	457	508	610

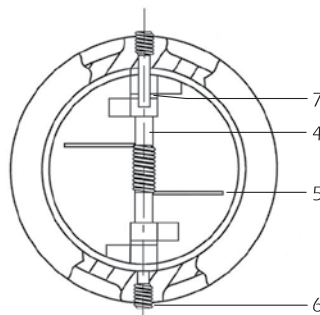
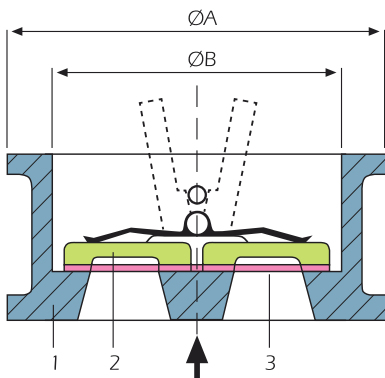

Applicable fluids:

Water, warm water, sea water, air and weak acid.

Flanges standard:

DIN PN 10/16

CV 20-25 CHECK VALVE

No.	Material	CV 20	CV 25
1	Body	Cast iron GG 25	Cast iron GG 25
2	Disc	AISI 316	Nickel coated GGG 40
3	Resilient Seat	EPDM	EPDM
4	Hinge Pin	AISI 316	AISI 316
5	Spring	AISI 304	AISI 304
6	Retainer Screw	Carbon steel	Carbon steel
7	Disc Bearing	Teflon	Teflon

INSTALLATION 1

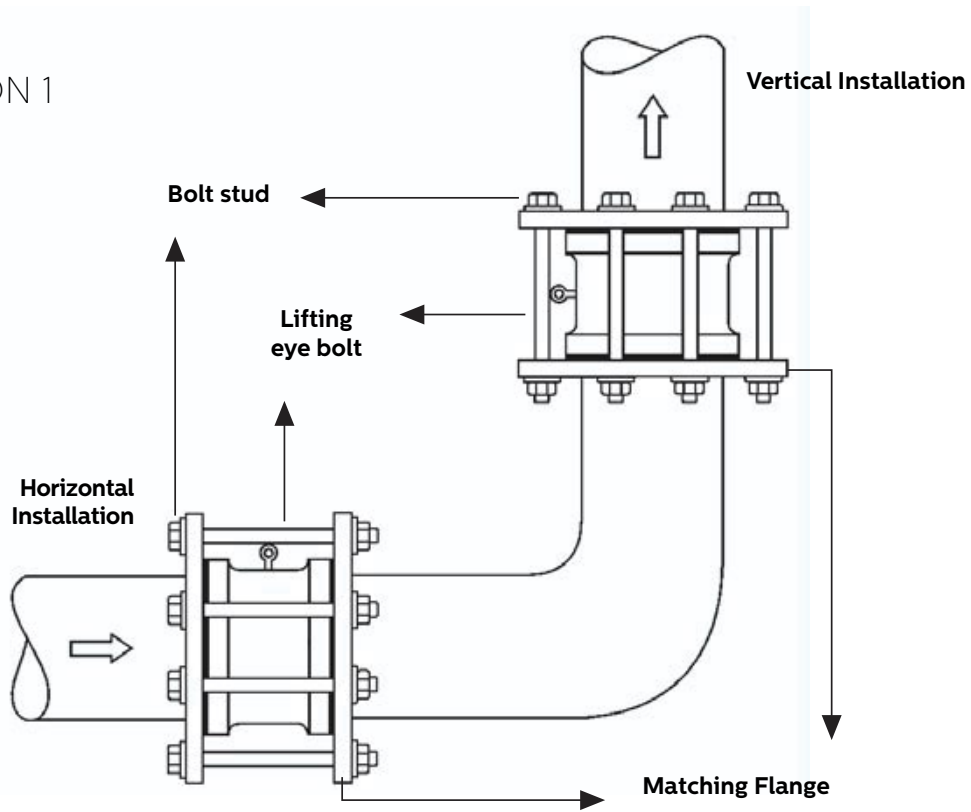

AYVAZ Dual Flap Wafer Check Valves need one sets of bolts (studs & nuts) to install it. These check valves installed in horizontal position must be installed with hinge pin in the vertical position to ensure proper operation. The valves larger than 6" (DN 150) are fitted with lifting eye bolts to provide easier handling and site safety.

CV20-25 CHECK VALVE

INSTALLATION 2

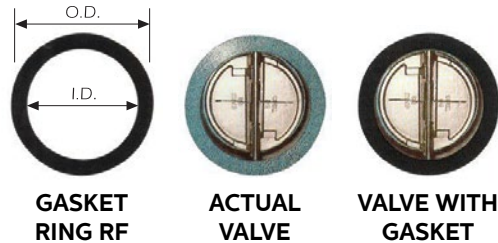

Use the correct dimension of gasket especially I.D. is important. The correct dimension of gasket (O.D.= valve external diameter $\varnothing A$ and I.D.= valve internal diameter $\varnothing B$) provide a perfect opening of disc and prevents leakage as well.

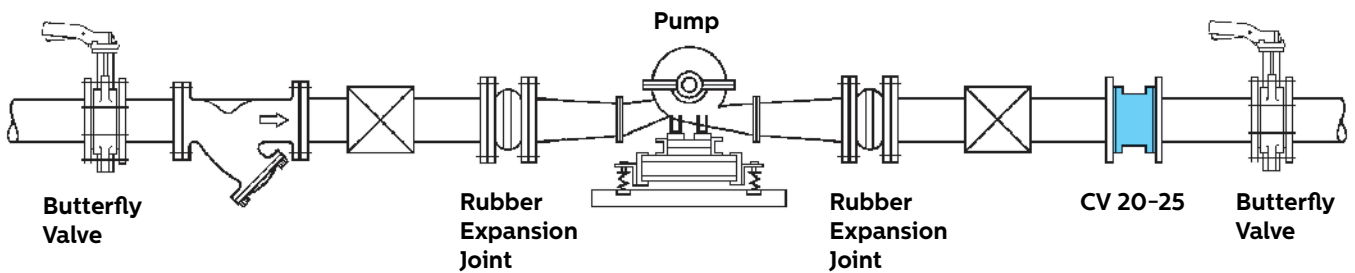

- Valve working under higher temperature, the pressure rating is reduced accordingly.
- Lifting eye bolt is fitted for size DN 200 & above.
- For other kinds of applicable fluids except the above, to which the check valve becomes applicable, please kindly consult to our SALES DEPARTMENT.



HEAD OFFICE - FACTORY

Atatürk Sanayi Bölgesi Hadımköy Mahallesi Mustafa İnan Caddesi No: 44 Arnavutköy - İSTANBUL
 Tel: +90 212 771 01 45 (pbx) | Fax: +90 212 771 47 27
 info@ayvaz.com | www.ayvaz.com

Cona
Caserta/Italy
 Tel: +39 0823 187 3988
 rmolaro@ayvaz.com

Ayvaz Germany
Viernheim/Germany
 Tel: +49 62046014399
 germany@ayvaz.com

Ayvaz Ukraine
Kiev/Ukraine
 Tel: +380 44 390 57 57
 info@ayvaz.com.ua

Tricorr
Warsaw/Poland
 Tel: +48 530 030 810
 +48 533 603 335
 tricorr@tricorr.eu

Ayvaz Azerbaijan
Baku/Azerbaijan
 Tel: +99 (455) 579-84-32
 ahayatov@ayvaz.com

Ayvaz Egypt
Cairo/Egypt
 Tel: +20 122 819 78 29
 andrew.eid@ayvaz.com

Ayvaz Gulf
Dubai/U.A.E
 Tel: +971 563550822
 +971 501306871
 mideast@ayvaz.com

Ayvaz China
Ningbo/China
 Tel: +86 152 5830 7361
 msahin@ayvaz.com

Ayvaz Kazakhstan LLP
Almaty/Kazakhstan
 Tel: +7 (727) 327 97 57
 info_kz@ayvaz.com

Ayvaz N
İsperih/Bulgaria
 Tel: +359 8431 27 32
 office@ayvaz-n.eu

Ayvaz Serbia
Belgrade/Serbia
 Tel: +381 61 658 70 52
 yakbiyik@ayvaz.com

Ayvaz Vietnam
HCMC/Vietnam
 Tel: +84 89 8508345

Ayvaz Americas
Rhode Island/USA
 Tel: +1 401 737 8380
 americas@ayvaz.com